

1
2
3
4
5
6
7
8
9
10
11
12
13
14
15
16
17
18
19
20
21
22
23
24
25
26
27
28
29
30
31
32
33
34
35
36
37
38
39
40
41
42
43
44
45
46
47
48
49
50

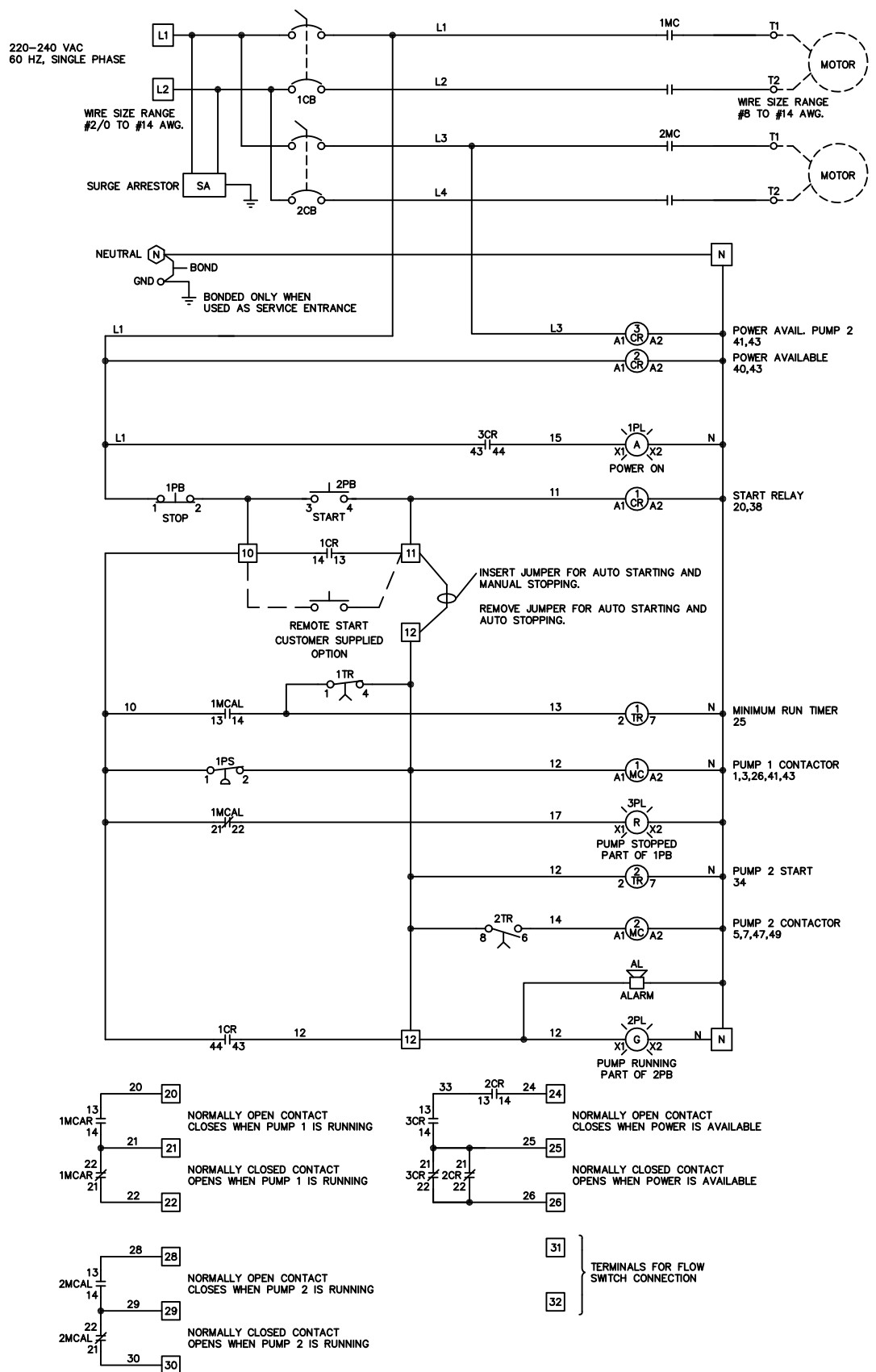

NOTES FOR FIELD WIRING:
 USE COPPER WIRING ONLY EXCEPT AT TERMINALS MARKED CU-AL.
 □ DENOTES TERMINALS ON 1T TERMINAL STRIP
 ⊕ DENOTES NEUTRAL TERMINAL BAR

DRAWN	RA	12-03-01	METRON, INC. DENVER, CO.
CHECK	W.L.K.	11-20-02	
APPD	Δ.K.	11-20-02	

SCHMATIC, MODEL RFP, SINGLE PHASE WITH CIRCUIT BREAKER, DUPLEX RESIDENTIAL FIRE PUMP CONTROLLER

CS33533B

SCALE N.T.S. SHEET 1 OF 1